

American Psychologist article: 1973 Voice to Skull Demonstration

Artificial microwave voice to skull transmission was successfully demonstrated by researcher Dr. Joseph Sharp in 1973, announced at a seminar from the University of Utah in 1974, and in the journal "American Psychologist" in the March, 1975 issue, article title "Microwaves and Behavior" by Dr. Don Justesen.

American Psychologist

Journal of the American Psychological Association
Volume 30 March 1975 Number 3

INSTRUMENTATION IN PSYCHOLOGY

- 191 INTRODUCTION: Instrumentation and Computer Technology: Applications and Influences in Modern Psychology.
Joseph B. Sidowski
- 197 COMPUTER TECHNOLOGY
- 199 Computers: Large-Scale Usage in the Balance. *Lee W. Gregg*
- 205 The Modern Minicomputer in Laboratory Automation. *N. John Castellan, Jr.*
- 212 Real-Time Computing in Psychology at the University of Colorado.
Daniel E. Bailey and Peter G. Polson
- 219 A General-Purpose Computer System for a Research and Development Center.
Robert J. Fitzhugh and Robert Glaser
- 226 Time-Shared Control Systems: Promises and Problems. *John F. King*
- 230 Interfacing the Experimenter to the Computer: Languages for Psychologists.
Ronald W. Wood, William F. Sette, and Bernard Weiss
- 239 Computer Graphics in Research: Some State-of-the-Art Systems.
R. Reddy, B. Rosen, S. Kriz, M. Powell, and B. Broadley
- 247 BIOPSYCHOLOGY
- 249 Instrumentation and Techniques in Physiological Psychology.
Michael M. Patterson
- 257 Recent NASA Contributions to Biomedical Telemetry. *Harold Sandler, Ernest P. McCutcheon, Thomas B. Fryer, Salvador Rositano, Richard Westbrook, and Peter Haro*

KENNETH B. LITTLE *Editor*

MIRIAM KELTY *Associate Editor*
RONALD B. KURZ *Associate Editor*
FRED STRASSBURGER *Associate Editor*
HAROLD P. VAN COTT *Associate Editor*
ANITA DEVIVO *Executive Editor and General Manager*
MARY BEYDA *Assistant to the Editor*
SUSAN K. REHR *Assistant Technical Editor*
KATHLEEN N. TABLER *Office Assistant*
LYNN D. SPIER *Publications Business Services*
ANNE REDMAN *Subscription Manager*

The *American Psychologist* is the official journal of the American Psychological Association and, as such, contains archival documents. It also publishes articles on current issues in psychology as well as empirical, theoretical, and practical articles on broad aspects of psychology. Manuscripts must adhere to the instructions on reference citations, preparation of tables and figures, manuscript format, etc., as described in the *Publication Manual of the American Psychological Association* (2nd ed.). Manuscripts that do not conform to the style set forth in the *Manual* will be returned for revision. When in doubt about practices of the Journal, authors should examine a recent issue.

Articles under consideration or accepted by another periodical of general circulation are not acceptable. Also, articles accepted for publication by this Journal may not be reprinted elsewhere without APA permission. Comments should be submitted no later than two months from the date of the issue containing an article on which comment is made in order to ensure timeliness.

Submit manuscripts in triplicate, accompanied by a 100-120-word abstract, to Kenneth B. Little, American Psychological Association, 1200 Seventeenth Street, N.W., Washington, D.C. 20036.

Statements contained in the *American Psychologist* are the personal views of the author and do not constitute APA policy unless so indicated. APA reserves the right to edit all copy and to refuse ads that are not in consonance with the principles of Title VII of the Civil Rights Act of 1964 (Equal Employment Opportunity).

Written permission must be obtained from the APA for copying or reprinting text of more than 500 words, tables, or figures. Address requests to the Permissions Office.

Copyright © 1975 by the American Psychological Association, Inc.

- 265 Two-Way Transdermal Communication with the Brain. *José M. R. Delgado, Vaino Lipponen, Gerhard Weiss, Francisco Del Pozo, José Luis Monteagudo, and Robert McMahon*
- 274 Intravenous Preparations for Self-Administration of Drugs by Animals. *Roy Pickens and Travis Thompson*
- 277 Cardiovascular Psychophysiology: Some Contemporary Methods of Measurement. *Paul A. Obrist, Claude J. Gaebelein, and Alan W. Langer*
- 285 Methods and Procedures for Monitoring and Recording Blood Pressure. *David T. Krausman*
- 295 Some Interactive Computer Applications in a Physiological Psychology Laboratory. *Richard A. Roemer*
- 299 Minicomputers in the Signal-Averaging Laboratory. *Emanuel Donchin and Earle Hefley*
- 313 SENSORY INFORMATION SYSTEMS
- 315 Eye-Movement Measurement Techniques. *Laurence R. Young and David Sheena*
- 331 An Advanced Eye-Movement Measuring and Recording System. *Richard A. Monty*
- 336 A Wide-Screen Projection System for Human Performance Studies. *R. A. F. Vunderink and A. F. Sanders*
- 340 The Laser as a Research Tool in Visual System Investigation. *Edward H. Polley, David J. Apple, and James W. Bizzell*
- 349 The Laser Optometer and Some Implications for Behavioral Research. *H. W. Leibowitz and R. T. Hennessy*
- 353 The Art of Tactile Communication. *Carl E. Sherrick*
- 361 CLINICAL AND APPLIED RESEARCH TECHNIQUES
- 363 Of Bread, Circuses, and Alpha Machines. *Robert L. Schwitzgebel and John D. Rugh*
- 371 Biofeedback Instrumentation: Soldering Closed the Loop. *David A. Paskewitz*
- 379 The Computer as Clinician. *Benjamin Kleinmuntz*
- 388 The Use of On-Line Computer Technology in a Mental Health Admitting System. *James H. Johnson and Thomas A. Williams*
- ★ 391 Microwaves and Behavior. *Don R. Justen*
- 402 Electroanesthesia and Electrosleep. *Clinton C. Brown*
- 411 The Potential of Acupuncture for the Behavioral Sciences. *David E. Breiter, Jay S. Cohen, Richard Kroening, Norman Levin, and Armin Sadoff*
- 415 Direct Measurement of Genital Responding. *James H. Geer*
- 419 Radio Telemetry in Clinical Psychology and Related Areas. *Donald R. Micklich*
- 426 Psychological Aspects of Aeronautical Flight Simulation. *Edward M. Huff and David C. Nagel*
- 440 Supertankers: Simulators for the Study of Steering. *W. A. Wagenaar*
- 445 BUYER'S GUIDE
Product Directory
Manufacturers and Suppliers Directory

Subscriptions: Subscriptions are available on a calendar-year basis only (January through December). Nonmember rates for 1975: \$12 domestic, \$13 foreign, \$2 single issue. Write to Subscription Section, APA. **Reprints:** Authors may order reprints of their articles from the printer when they receive galley proofs. **Back Issues and Back Volumes:** For information regarding back issues or back volumes write to Order Department, APA. **Microform Editions:** For information regarding microform editions write to any of the following: Johnson Associates, Inc., P.O. Box 1017, Greenwich, Connecticut 06830; University Microfilms, Ann Arbor, Michigan 48106; or PsycInfo Microfilms, Princeton, New Jersey 08540. **Change of Address:** Send change of address notice and a recent mailing label to the attention of the Subscription Section, APA, 30 days prior to the actual change of address. Undelivered copies resulting from address changes will not be replaced; second-class mail is not forwarded unless subscribers notify the local post office in writing that they will guarantee second-class forwarding postage. Published monthly in one volume per year, 12 issues, by the American Psychological Association, Inc., 1200 Seventeenth Street, N.W., Washington, D.C. 20036. Printed in the U.S.A. Second-class postage paid at Washington, D.C., and additional mailing offices.

The American Psychological Association's purpose of science, at large. It by holding al journals for p

various
: PAU
progress.
s, such
process
tiveness
groups
urn, be
ke deci-
of favor-
ropriate

gust 1974.

ck, T., &
depression.
t.

Holman,
s History
of Clinical

tal health:
Gianturco
n systems:
inger, 1974.
mprovement
s. Journal
s, 43-48.
n engineer:
and Com-

Further de-
psychiatric
1969, 125

ers, B. A
aking and
s, 1972, 5.

Victor Frankenstein surgically fathered the famous fictional monster, but the fiend was conceptually mothered if not physically spawned by electricity in the form of lightning from the heavens. Perhaps unwittingly, perhaps intuitively, author Mary Shelley (1831) touched a deep truth in the maternal metaphor: Life did originate from electrical discharges into the primeval fog. Indeed, life continues to preserve in all of its earthly forms from the most primitive cell to the most complex organism an elemental dependence on electrical phenomena. Understandably, the curiosity of the scientist about the electrobiological goings-on of the earth's flora and fauna is shared by the layman. A large popular literature is accumulating and embraces experiments and anecdotes that range from the ostensibly respectable to the seemingly bizarre. Recently published texts by Tompkins and Bird (1973) and by Burr (1972, 1973) are not only exemplars of the literature but are rich sources of reference materials. One reads, for example, that plants have nervous systems that yield differing electrical signals on "stimulation" by *kind* or *malevolent thoughts* of human beings (Backster, 1968). One also reads that many Soviet scientists are giving credence and careful study to ESP and related phenomena, not in defiance of Marxian dictates of materialism but quite in keeping with them. The Soviets are championing earlier theoretical notions of Georges Lakhovsky (1934) to the effect that each plant or animal cell is an oscillatory system capable of transmitting and receiving high-frequency electromagnetic energy over a distance. While affirming that electrical events are

This article is based on materials presented in a seminar to the faculties of Psychology and Engineering at the University of Utah (Salt Lake City, Utah) on August 21, 1974. The author's research program is supported by the Veterans Administration and by U.S. Public Health Service Grant FD00650. Acknowledged in the preparation of the manuscript are E. L. Wike and C. L. Sheridan, for a critical reading; Kay Wahl, for artwork; and Lynn Bruetsch and Virginia Florez, for typing. I also thank John Osepchuk of the Raytheon Corporation for his searching criticism of the manuscript; our opinions differ, his advice is appreciated.

Requests for reprints should be sent to Don R. Justesen, Laboratories of Experimental Neuropsychology, Veterans Administration Hospital, Kansas City, Missouri 64128. The author is also at the Department of Psychiatry, Kansas University Medical Center, Kansas City, Kansas 66103.

author is now at the Department of Psychiatry, Kansas University Medical Center, Kansas City, Kansas 66103.

Microwaves and Behavior

DON R. JUSTESEN

Laboratories of
Experimental Neuropsychology,
Veterans Administration Hospital,
Kansas City, Missouri



Below image gives the description of the successful modulation. (Note that the fidelity of current-day voice to skull transmission is much higher, after three-plus decades of apparent development.):

water, for example, in carbon-impregnated plastic and in crumpled sheets of aluminum foil. Even subjects who cannot hear microwaves when directly radiated by them can readily perceive clicking sounds when a piece of energy-absorbing material is interposed between the head and a radiator of pulsed microwave energy. Oddly enough, the mass of the interposed material does not seem to be too critical; I successively used smaller and smaller pieces of material as sonic transducers until it was necessary to impale tiny pieces on a toothpick, yet the clicking sounds induced in the material by microwave pulses were clearly audible to me.

The demonstration of sonic transduction of microwave energy by materials lacking in water lessens the likelihood that a thermohydraulic principle is operating in human perception of the energy. Nonetheless, some form of thermoacoustic transduction probably underlies perception. If so, it is clear that simple heating as such is not a sufficient basis for the Frey effect; the requirement for pulsing of radiations appears to implicate a thermodynamic principle. Frey and Messenger (1973) demonstrated and Guy, Chou, Lin, and Christensen (1975) confirmed that a microwave pulse with a slow rise time is ineffective in producing an auditory response; only if the rise time is short, resulting in effect in a square wave with respect to the leading edge of the envelope of radiated radio-frequency energy, does the auditory response occur. Thus, the rate of change (the first derivative) of the wave form of the pulse is a critical factor in perception. Given a thermodynamic interpretation, it would follow that information can be encoded in the energy and "communicated" to the "listener." Communication has in fact been demonstrated. A. Guy (Note 1), a skilled telegrapher, arranged for his father, a retired railroad telegrapher, to operate a key, each closure and opening of which resulted in radiation of a pulse of microwave energy. By directing the radiations at his own head, complex messages via the Continental Morse Code were readily received by Guy. Sharp and Grove (Note 2) found that appropriate modulation of microwave energy can result in direct "wireless" and "receiverless" communication of speech. They recorded by voice on tape each of the single-syllable words for digits between 1 and 10. The electrical sine-wave analogs of each word were then processed so that each time a sine wave crossed zero reference in the negative direction, a brief pulse of microwave energy was trig-

gered. By radiating themselves with these "voice-modulated" microwaves, Sharp and Grove were readily able to hear, identify, and distinguish among the 9 words. The sounds heard were not unlike those emitted by persons with artificial larynxes. Communication of more complex words and of sentences was not attempted because the averaged densities of energy required to transmit longer messages would approach the current 10 mW/cm² limit of safe exposure. The capability of communicating directly with a human being by "receiverless radio" has obvious potentialities both within and without the clinic. But the hotly debated and unresolved question of how much microwave radiation a human being can safely be exposed to will probably forestall applications within the near future.

The U.S. limit of 10 mW/cm² is actually an order of magnitude below the density that many investigators believe to be near the threshold for thermal hazards (Schwan, 1970). There are two camps of investigators in the United States, however, who believe that the limit is not sufficiently stringent. In the first camp of conservatives are those who accept the Soviet's belief that there are hazardous effects unrelated to heating from chronic exposures to fields of low density (< 1 mW/cm²); some agree with Milton Zaret (1974), a New York ophthalmologist, who holds that severely debilitating subcapsular lesions of the eyes may develop years, even decades, after exposure to weak microwave fields. Others tend to reject the notion that weak microwave fields produce this anomalous cataract, because of lack of substantiating evidence from the clinic or the laboratory (Appleton & Hirsch, 1975). But these conservatives are possessed of a vague unease simply because the Soviet's limit of continuous permissible exposure is three orders of magnitude below that of the United States.³

The other camp of conservatives tends to reject the possibility of hazardous nonthermal effects,

³ The Soviet's exposure limit of 10 μ W/cm² is three orders of magnitude below the exposure limit in the United States, but a different, that is, *emission*, limit holds for microwave ovens purchased for use in the American kitchen. In the United States at the present time, a newly purchased microwave oven may not emit radiation at a density greater than 5 mW/cm² as measured at a distance of 5 cm from the oven's surface. A user who stands 1 m from an oven that emits energy at the maximum permissible quantity would probably be exposed to a density of only a few microwatts per square centimeter—this is because electromagnetic energy when radiated from a point source attenuates markedly as it propagates through space.

but hol
microw
derstan
reader
establis
part ge
in the
(see A
tainin
electric
human
termec
in whi
only
condit
high
for es
near
reflec
ergy
tiona
deter
direc
mea-
sign
in :
engi
Kor
C
rat:
ful:
to
Ac
fo
af
19
ar
ta
S
d
w
f
c

Below image illustrates Dr. Joseph Sharp's voice to skull modulation method described above in the American Psychologist journal article:

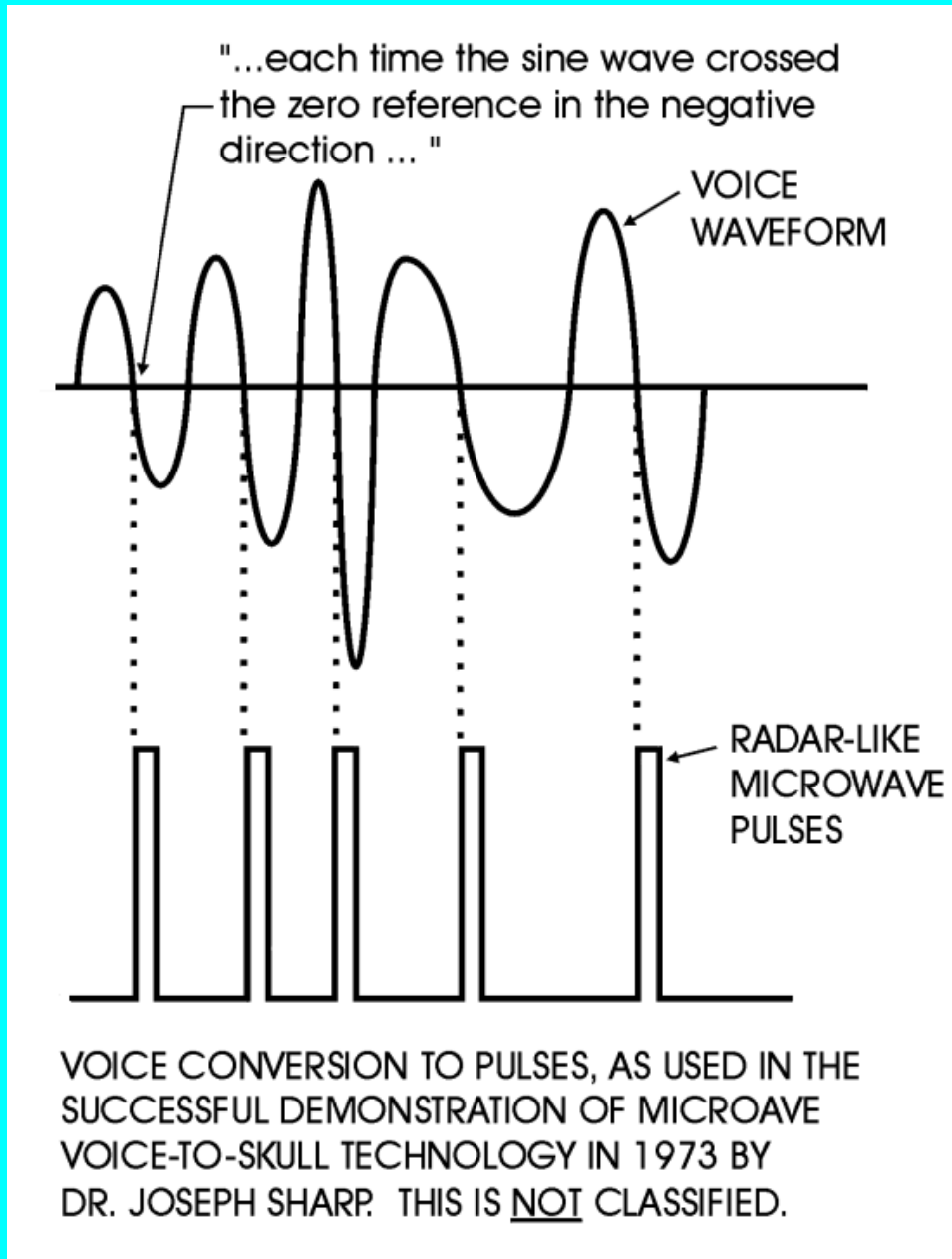

Below image shows a way to demonstrate Dr. Joseph Sharp's voice to skull modulation method, converting speech or music to a string of pulses. In Sharp's experiment, the pulses were microwave signals, similar to radar, but the demo circuit below puts out simple DC pulses which can be fed to a speaker. It emits no microwave signals and is totally safe.

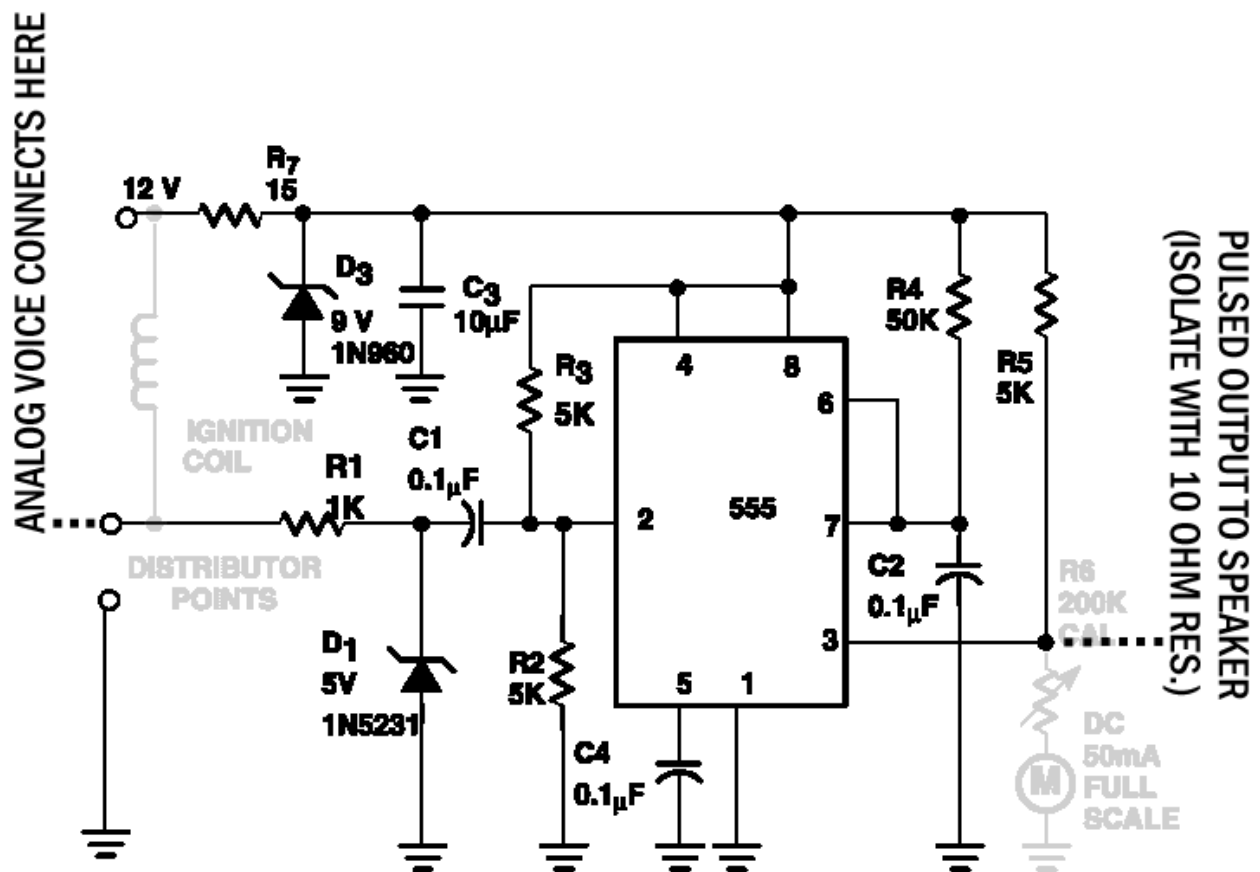

USING A 555 CHIP TACHOMETER DRIVER CIRCUIT TO SIMULATE DR. JOSEPH SHARP'S MICROWAVE VOICE TO SKULL VOICE-TO-PULSES CONVERSION METHOD